

# Smeigiamas temperatūros jutiklis TJ-ST

Penetration temperature sensor TJ-ST is inextricably connected to the cable. It is designed for temperature measurement from -30 °C to +180 °C. T type handle suits for easier holding and penetration into the product. The needle and handle are made from stainless steel.

Temperature sensor construction designed for usage in food and beverage, pharmaceutical, chemistry and other industries.

Various sizes are available depending on customer requirements and drawings.

## Product code

		<b>Sensing element quantity</b>	
1	<input type="text"/>	1	Single Pt 100, Pt1000
		2	Double Pt100, Pt1000
		<b>Sensing element</b>	
		Pt100	Pt100
		Pt100	Pt1000
2	<input type="text"/>	Other parameters acc. to requirements	
		<b>Accuracy</b>	
		A or B	A or B
3	<input type="text"/>	Other parameters acc. to requirements	
		<b>Diameter of measuring part D, mm</b>	
		4	4 mm
4	<input type="text"/>	Other parameters acc. to requirements	
		<b>Length of measuring part Lp, mm</b>	
		100	100 mm
5	<input type="text"/>	Other parameters acc. to requirements	
		<b>Steel</b>	
		304	Stainless steel 1.4301 (AISI 304)
		316L	Stainless steel 1.4404 (AISI 316L)
6	<input type="text"/>	Other parameters acc. to requirements	
		<b>Sensor connection</b>	
		2	2-wires
		3	3-wires
7	<input type="text"/>	Other parameters acc. to requirements	
		<b>Cable isolation material</b>	
		P	PVC
		S	Silicon
8	<input type="text"/>	Other parameters acc. to requirements	
		<b>Cable length Lk, m</b>	
		3	3 m
9	<input type="text"/>	Other parameters acc. to requirements	

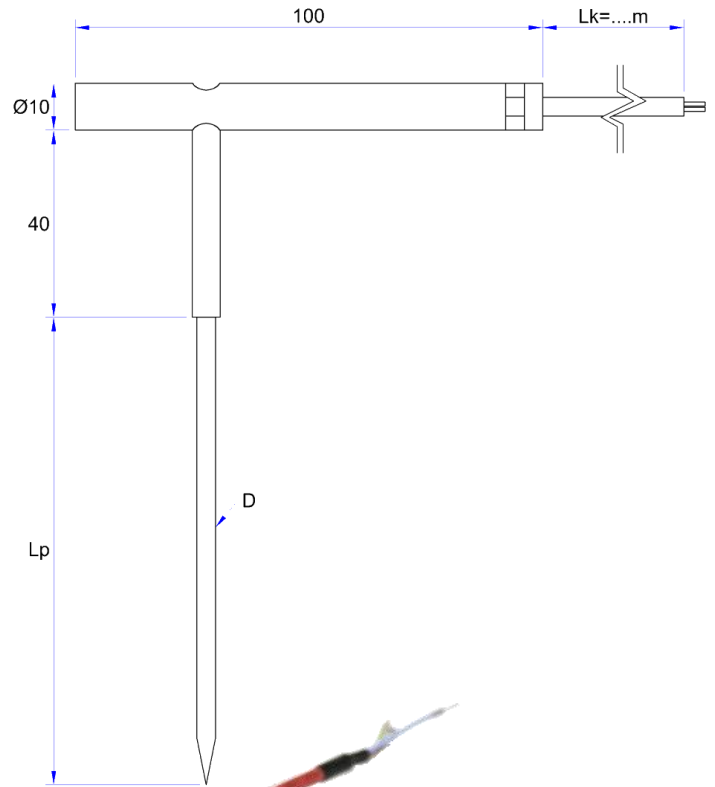

		<b>1</b>	<b>2</b>		<b>3</b>		<b>4</b>		<b>5</b>		<b>6</b>		<b>7</b>	<b>8</b>	<b>9</b>
<b>TJ-ST</b>	-			/		-		x		-		-			

e.g. **TJ-ST-Pt100/B-4x100-316L-3S3**

Temperature sensor **TJ-ST** with **Pt100** class **B** sensor, measuring part diameter **Ø 4**, measuring part length **100 mm**, stainless steel **316L**, sensor connection **3**, cable isolation type **S** (temperature range -30 °C...+180 °C), cable length **3 m**.